

Constant Voltage Transformers

AVAILABLE FROM
NEPEAN ELECTRONICS

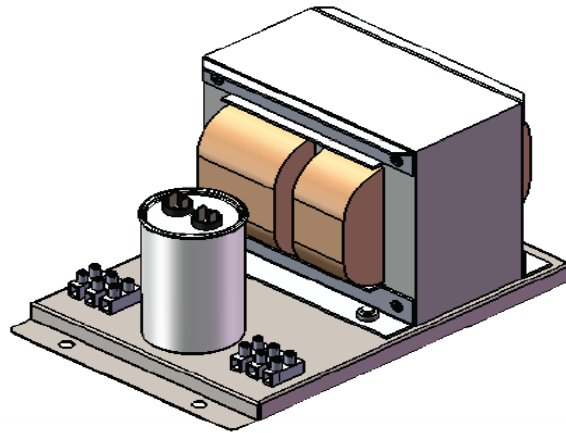

NEPEAN Power is a proven leader in the supply and manufacture of quality engineered solutions, products and technologies. Established in 1994, through the commitment of our dedicated team we have become a supplier of choice.

The NEPEAN Power Constant Voltage Transformer has a wide application, particularly where reliability and inherent regulating ability against line voltage changes are of prime importance.

The output of the constant-voltage transformer is essentially a square wave, which is desirable for rectifier output applications while, also having good circuit characteristics.

Features

- Bottom plate is built of powder coated steel. Thickness is 1.5mm.
- Mounting holes are unknown and subject to customer's confirmation.
- Length and gauge of wires suit the transformer.
- Weight of the whole asm is around 15KGS.

Ordering Information

Part Number	Description
T99-1-1CV-0ES	110/55-0-55 1kVA single phase constant voltage transformer with centre tap ϕ earth screen
T89-1-1CV-0ES	240/55-0-55 1kVA single phase constant voltage transformer with centre tap ϕ earth screen
T79-1-1CV-0ES	415/55-0-55 1kVA single phase constant voltage transformer with centre tap ϕ earth screen

