

Real Time Clock

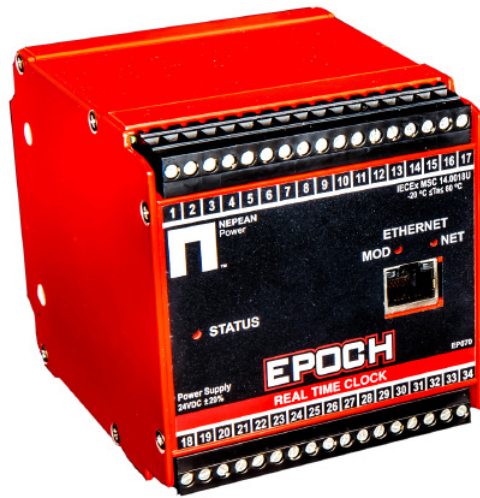

AVAILABLE FROM
NEPEAN ELECTRONICS

NEPEAN Power is a proven leader in the supply and manufacture of quality engineered solutions, products and technologies. Established in 1994, through the commitment of our dedicated team we have become a supplier of choice.

The EP070 is a microprocessor controlled module that features a fully functional Real Time Clock designed to output the time and date in ISO 8601 format. It employs an internal certified battery backup to maintain time and date during power cycles.

The EP070 features an internal network communications controller using EtherNet/IPTM protocol to set and retrieve the time and date data.

The data available includes Year, Month, Day, Hours, Minutes, Seconds, and milliseconds. The EtherNet/IPTM port allows simple setup of IP address and communication with other industrial devices on the local network such as PLC and HMI units.

Features

- Approved for explosive atmospheres Zone 0 Group I and Group IIC T4
- EtherNet/IP communication Interface with a standard RJ45 socket
- Battery Back-up Power for continuous time stamps
- Millisecond precision timestamp output in ISO 8601 Time Format
- EtherNet/IP LED status indication

Communications

Network communication for the EP070 unit is facilitated through the use of a standard RJ45 socket supporting the EtherNet/IPTM protocol. Physical layer support is via standard Auto-Sensing 10 Base-T / 100Base-TX Ethernet and includes Ethernet Activity and EtherNet/IPTM status LED indicators.

The EtherNet/IPTM (EIP) interface consists of an input assembly object and an output assembly object. The module will use a BOOTP server if it is available.

If the BOOTP request fails, the EP070 will revert to using the IP address in non-volatile memory, this will be the previously assigned IP Address. The time out occurs after approximately 30 seconds.

Connections

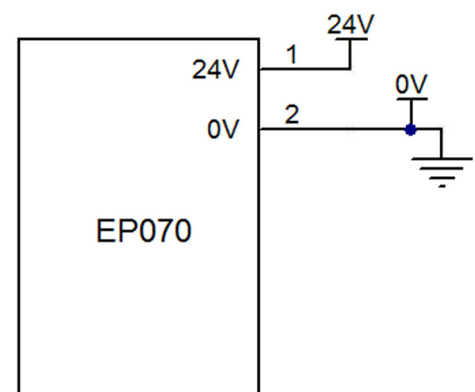

- PIN1/2 Connected to a earth referenced 24VDC supply
- Cat5 compatible network connection to the Ethernet Port with suitable IP address allocation

Ordering Information

Part Number	Description
EP070	Real Time Clock

Real Time Clock

Input Assembly Object

The input assembly object (T → O) can be accessed using the following parameters (Hexadecimal):

- Service Code: 0E
- Class: 04
- Instance: 65
- Attribute: 03

The size of the input assembly object is 34 bytes consisting of 17 words. All the data items are 16 bit unsigned integers. The data in the input assembly object is refreshed every 100ms.

Field	Description
EIP Status	0 indicates unit comms is healthy
EIP Heartbeat	Unsigned 16-bit value incrementing approx every 100ms
Date and Time	24-hour format: [YYYY] [MM] [DD] [hh] [mm] [ss] [ms]
	MAJOR.MINOR
Firmware version	MAJOR (Upper byte)
	MINOR (lower byte)

Output Assembly Object

The output assembly object (O → T) can be accessed using the following parameters (Hexadecimal):

- Service Code: 0E
- Class: 04
- Instance: 66
- Attribute: 03

The size of the output assembly object is 16 bytes consisting of 8 words. All the data items are 16 bit unsigned integers.

Field	Description
Run/Idle (R/I)	Needs to be set to 1 for the data written in the output assembly table
Date and Time	24-hour format: [YYYY] [MM] [DD] [hh] [mm] [ss] [ms]
	Needs to be set to 1 for the data written in the output assembly table
WR Bit	Needs to be set to 1 for the data written in the output assembly table

Technical Specifications

Supply Voltage	24VDC ± 20%
Supply Current	220mA Nom. (500mA Peak)
Terminals	Plug-in 0.2-2.5mm ²
Communications	EtherNet/IP™
Approvals	IECEX MSC 14.0018U
Mounting	DIN Rail (EN 50022)
Dimensions	97mm x 92mm x 120mm (HxWxD)

Certification

The RTC/Battery module installed in this device is certified to IEC 60079.11:2011 (AS/NZS 60079.11:2011). The unit is certified as:

- When Um of 250 VAC (24VDC) not connected, Ex ia I IIC T4 Ga Ma
- When Um of 250 VAC (24VDC) connected, [Ex ia Ga Ma] I IIC

Unit must be covered under additional Ex protection when powered in a Hazardous Zone.

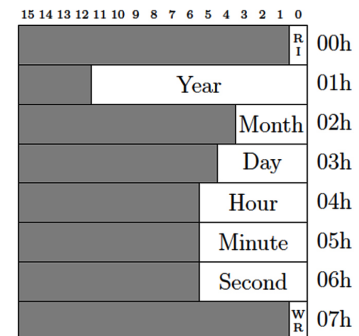
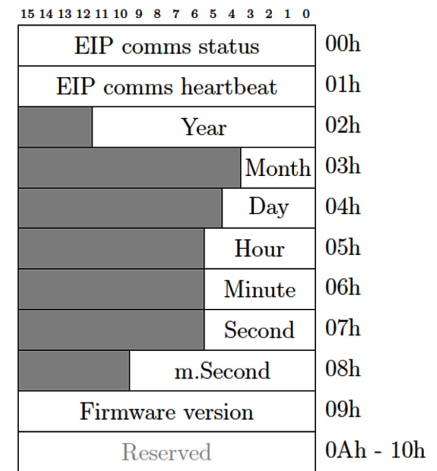

NOTE: Both the R/I and the WR bits need to be set for the data to be written into the output table



NEPEAN
Power

www.nepeanpower.com

For more information please contact:

P: +61 2 4088 2790

E: power@nepean.com