



Strobe Sounder

AVAILABLE FROM
NEPEAN ELECTRONICS



NEPEAN Power is a proven leader in the supply and manufacture of quality engineered solutions, products and technologies. Established in 1994, through the commitment of our dedicated team we have become a supplier of choice.

The NEPEAN Power Strobe Sounder is a conventional, combined sound and strobe beacon. The strobe sounder is suitable for outdoor applications with an IP65 rating. The Strobe Sounder is designed for external use, having a composite of polycarbonate and ABS plastic making it both durable and weather resistant.

Further weather resistance comes from the internal circuit coating used to resist moisture. This strobe sounder uses high brightness LED's and a durable piezoelectric transducer.

Features

- Designed for outdoor use
- Easy to wire and install
- Strobe and alarm type is configurable
- Distinguishable alarms can be set for different types of emergencies
- Adjustable volume

Technical Specifications

Part Number	AW-CSS2166-4/110	AW-CSS2166-4/24
Operating Voltage	110VAC	24VDC
Operating Current		≤100ma
Dimensions	122mm x 128mm x 100mm	
Weight	0.32kg	
Product Material	Hard Plastics	
Product Colour	Red	
LED Colour	Red	
Environment Application	Outdoor (IP65)	
Flash Rate	120 times/ minute	
Temperature Range	-10°C ~ +55°C	
Humidity Range	0% ~ 95%RH	
Volume	95 ~ 115dB (Adjustable)	
Alarm Type	8 Options	
Wiring	Supply+	+24V DC
	Supply-	-110V DC

Strobe Sounder

Dimensions

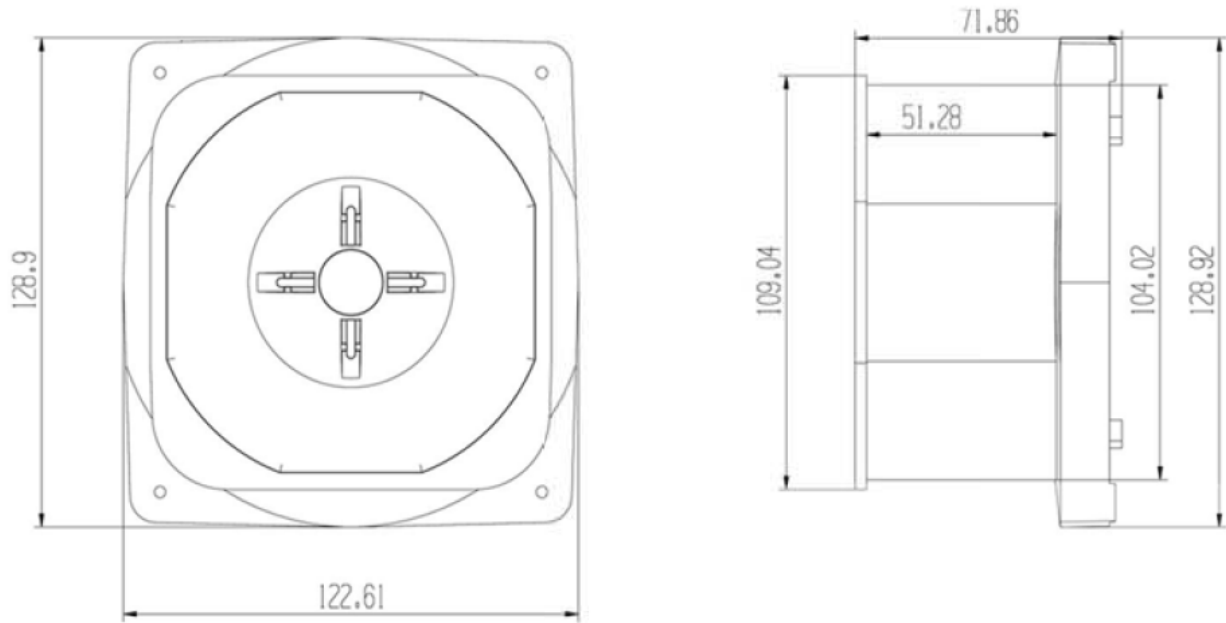

Wiring and Jumper Setting

1. Connect sound and GND for sound output only, option of 8 tones
2. Connect together and GND for flash light with sound output, option of 8 tones
3. Connect light and GNS for just flash light output only

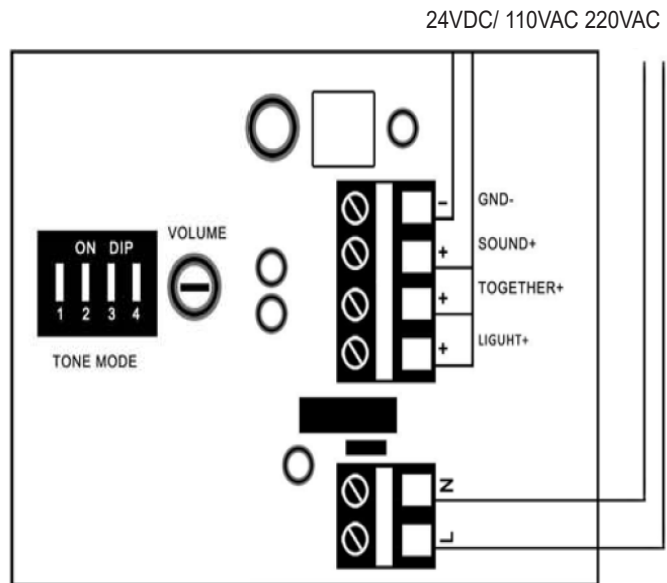

Use Guidance

Ordering Information

Part Number	Description
AW-CSS2166-4/110	110VAC Sounder with Strobe
AW-CSS2166-4/24	24VDC Sounder with Strobe

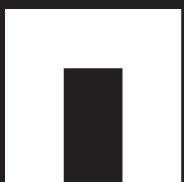

NEPEAN
Power

www.nepeanpower.com

For more information please contact:

P: +61 2 4088 2790

E: power@nepean.com